

## Air Heaters for the RV Market

Air Top 2000 STC and Air Top Evo 40/55



### Diesel powered air heaters:

Webasto air heaters provide heating output via continuous heating power output via stepless modulation, ensuring constant temperatures. The heater operates quietly and consumes very little power and fuel.

The air heater can be used as a stand-alone heating solution or as an add-on system to existing heating solutions. Therefore Webasto offers heaters with different power outputs, ranging from 2 kW up to 5.5 kW. All Webasto Air Top heaters can be either mounted outside, in the double-floor or inside the vehicle.

### Key benefits at a glance:

- Optimum heat output at high altitudes thanks to integrated altitude sensor (Evo range) or via MultiControl (Air Top 2000 STC)
- Heating power from 2 kW to 5.5 kW
- Very compact heater for easy and fast installation
- Smooth blower and burner operation for low noise and fuel consumption
- Hot air is distributed through a ducting system into the motor home, ensuring a constant temperature
- Precise and stepless cabin temperature control
- Very fast heat-up phase
- Diesel-fueled, directly fed from the tank
- Available as petrol version
- More space inside and less weight thanks to significantly reduced LPG bottles
- More space inside because gas bottle capacity can be reduced significantly
- Heating while driving allowed in all countries

## Application concept

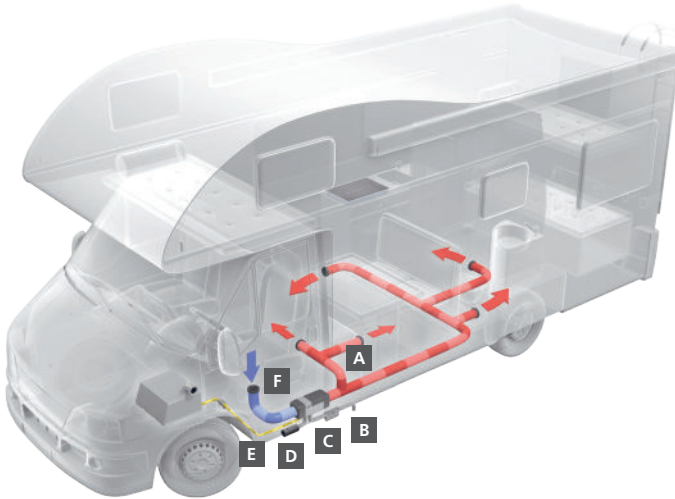

- A** Hot air outlet: Hot air is distributed through a ducting system
- B** Exhaust pipe
- C** Silencer
- D** Combustion air intake
- E** Fuel supply leads to the vehicle fuel tank or fuel return line
- F** Fresh air intake

## Technical specifications

Now also available as petrol version

	Air Top 2000 STC		Air Top Evo 40	Air Top Evo 55
Heat power (kW)	0.9 – 2.0	1.0 – 2.0	1.5 – 3.5/4.0*	1.5 – 5.0/5.5**
Fuel	Diesel	Petrol	Diesel	Diesel
Fuel consumption (l/h)	0.12 – 0.24	0.14 – 0.27	0.18 – 0.43/0.49*	0.18 – 0.61/0.67**
Rated voltage (V)	12	12	12	12
Rated power consumption (W)	13 – 30	15 – 30	15 – 40/55*	15 – 95/130**
Air flow against 0.5 mbar (m³/h)	93	93	132/140*	200/220**
Dimensions L x W x H (mm)	310 x 120 x 118	310 x 120 x 118	423 x 148 x 162	423 x 148 x 162
Weight (kg)	2.6	2.6	5.9	5.9
Altitude compensation (m)	1,500 With MultiControl: 2,200		2,200 High Altitude: 5,500	2,200

\* Increased heat output ("Boost") possible for max. 6 hours.

\*\* Increased heat output ("Boost") possible for for max. 30 minutes.

## Controls



MultiControl



ThermoConnect App

The MultiControl sets new standards in terms of its modern design and user-friendliness that allows fast and intuitive operation. It includes features like an immediate start button, the ventilation function and fault code display. You can program up to three start times per day for your heater which allows the best individual comfort.

Even greater comfort with our innovative Webasto ThermoConnect App. Run your water or air heater easily with a smartphone via App for iOS and Android device.